



**TRUE FOOD SERVICE
EQUIPMENT, INC.**

2001 East Terra Lane • P.O. Box 970 • O'Fallon, Missouri 63366
 (636)240-2400 • Fax (636)272-2408 • (800)325-6152 • Intl Fax# (001)636-272-7546
 Parts Dept. (800)424-TRUE • Parts Dept. Fax# (636)272-9471 • www.truemfg.com

Project Name: _____

A/A #

Location: _____

Item #: _____ Qty: _____

S/S #

Model #: _____

Model:
THDC-4SF

Dipping Cabinet:
Slim Freezer



THDC-4SF

- ▶ True's horizontal ice cream dipping cabinets are uniquely designed to provide the user maximum functional reliability with the flexibility to both store and serve ice cream product.
- ▶ Cold wall refrigeration system. Maintains -10°F to +8°F (-23.3°C to -13.3°C).
- ▶ Exclusive, reverse condensing fan motor(s) reduces maintenance costs and optimizes cabinet performance.
- ▶ Designed to hold ten (10) 9½" (242 mm) diameter, 3 gallon (12 L) ice cream containers.
- ▶ Dual access, removable lids.
- ▶ NSF-7 compliant for open food product.
- ▶ Entire cabinet structure is foamed-in-place using high density, CFC free, polyurethane insulation.

ROUGH-IN DATA

Specifications subject to change without notice.

Chart dimensions rounded up to the nearest 1/8" (millimeters rounded up to next whole number).

Model	Lids	Capacity		Cabinet Dimensions (inches) (mm)			HP	Voltage	Amps	NEMA Config.	Cord Length (total ft.) (total m)	Crated Weight (lbs.) (kg)
		(Cu. Ft.) (liters)	3 gal. 12 L Cans	L	D	H*						
THDC-4SF	4	10.1 287	10	54 1/8 1375	21 534	32 1/4 820	1/4	115/60/1	6.1	5-15P	9 2.74	305 139

* Height does not include 7/8" (23 mm) for lid handles.



APPROVALS:

AVAILABLE AT:

Model:
THDC-4SF

Dipping Cabinet:
Slim Freezer



STANDARD FEATURES

DESIGN

- True's horizontal ice cream dipping cabinets are uniquely designed to provide the user maximum functional reliability with the flexibility to both store and serve ice cream product.

REFRIGERATION SYSTEM

- Factory engineered, self-contained, capillary tube system using environmentally friendly (CFC free) R404A refrigerant.
- Cold wall refrigeration system. Maintains -10°F to +8°F (-23.3°C to -13.3°C).
- Exclusive, reverse condensing fan motor(s) reduces maintenance costs and optimizes cabinet performance.
- Condensing unit located behind rear grill on right side; slides out for easy maintenance.
- Manual defrost system; drain tube with hose connector conveniently located behind rear access panel.

CABINET CONSTRUCTION

- Exterior - non-peel or chip white laminated vinyl clad steel; durable and permanent.

- 300 series stainless steel top. The finest stainless steel for higher tensile strength for increased durability.
- Interior - high quality white enamel powder coat finish on galvanized steel. Stainless steel lid liner.
- Insulation - entire cabinet structure is foamed-in-place using high density, CFC free, polyurethane insulation.
- Heavy duty, galvanized steel base rail with white enamel powder coat finish.

LIDS

- Hinged, 300 series stainless steel dipping compartment service lid with handles. Perimeter wiper gasket for improved seal.
- Anti-condensate heaters reduce the potential for condensation build-up.

MODEL FEATURES

- Designed to hold ten (10) 9½" (242 mm) diameter, 3 gallon (12 L) ice cream containers.
- NSF-7 compliant for open food product.

ELECTRICAL

- Unit completely pre-wired at factory and ready for final connection to a 115/60/1 phase, 15 amp dedicated outlet. Cord and plug set included.



RECOMMENDED OPERATION CONDITIONS

- THDC models are designed to operate in an air conditioned environment where temperatures do not exceed 75°F and 55% relative humidity.

OPTIONAL FEATURES/ACCESSORIES

- Upcharge and lead times may apply.
- ☐ 6" (153 mm) standard legs.
 - ☐ 6" (153 mm) seismic/flanged legs.
 - ☐ 2½" (64 mm) diameter castors.

PLAN VIEW

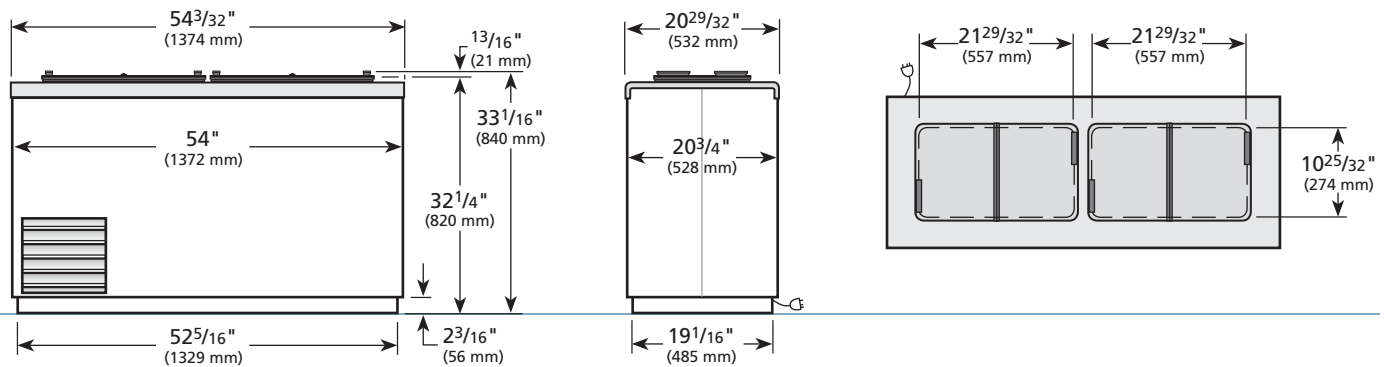

ELEVATION

RIGHT VIEW

PLAN VIEW

WARRANTY

One year warranty on all parts and labor and an additional 4 year warranty on compressor. (U.S.A. only)

METRIC DIMENSIONS ROUNDED UP TO THE NEAREST WHOLE MILLIMETER
 SPECIFICATIONS SUBJECT TO CHANGE WITHOUT NOTICE



Model	Elevation	Right	Plan	3D
THDC-4SF				

TRUE FOOD SERVICE EQUIPMENT