



TRUE FOOD SERVICE EQUIPMENT, INC.

St. Charles Industrial Center • P.O. Box 970 • O'Fallon, Missouri 63366
(636)240-2400 • FAX (636)272-2408 • (800)325-6152 • www.truemfg.com
Parts Dept. (800)424-TRUE • Parts Dept. FAX# (636)272-9471

Project Name: _____

A/A #

Location: _____

Item #: _____ Qty: _____

SIS #

Model #: _____

Model:
THF-29FL

Horizontal Freezer: Glass Flat Lid



Shown with optional novelty wire baskets.

THF-29FL

- ▶ True's horizontal freezers are uniquely designed to promote high-profit frozen novelties in high impulse retail traffic areas. Ideal for bolstering incremental sales increase of frozen merchandise and seasonal specialties.
- ▶ Cold wall, environmentally friendly (134A) refrigeration system. Maintains -10°F (-23.3°C), ideal for both ice cream and frozen food.
- ▶ Exterior - non-peel or chip white laminated vinyl with black trim; durable and permanent.
- ▶ Interior - NSF approved, white aluminum with 300 series stainless steel floor.
- ▶ Tempered, hard coated, "Low-E" glass slide lids. Reduces solar heat gain, enhances energy efficiency and minimizes condensation.
- ▶ Locks standard, provide security, prevents theft.
- ▶ Convenient defrost drain.
- ▶ 1½" (39 mm) dual swivel castors.

ROUGH-IN DATA

Specifications subject to change without notice.
Chart dimensions rounded up to the nearest 1/8" (millimeters rounded up to next whole number).

Model	Lids	Capacity (Cu. Ft.) (liters)	Cabinet Dimensions (inches) (mm)			HP	Voltage	Amps	NEMA Config.	Cord Length (total ft.) (total m)	Crated Weight (lbs.) (kg)
			L	D	H*						
THF-29FL	2	7.0 199	29½ 750	25¾ 655	31¾ 807	¼ 1/3	115/60/1 230-240/50/1	4.0 2.1	5-15P ▲	9 2.74	175 80

* Height does not include 2 1/8" (54 mm) for castors.

▲ Plug type varies by country.



APPROVALS:

Model:
THF-29FL

Horizontal Freezer:
Glass Flat Lid



STANDARD FEATURES

DESIGN

- True's horizontal freezers are uniquely designed to promote high-profit frozen products in high impulse retail traffic areas. Ideal for bolstering incremental sales increases for frozen merchandise and seasonal specialties.

REFRIGERATION SYSTEM

- Factory engineered, self-contained, capillary tube system using environmentally friendly (CFC free) 134A refrigerant.
- Cold wall refrigeration system maintains -10°F (-23.3°C) cabinet temperature, ideal for both ice cream and frozen food.
- Condensing unit is accessed from behind grill on right side; slides out for easy maintenance.
- Manual defrost system; convenient drain located on front of cabinet.

CABINET CONSTRUCTION

- Exterior - non-peel or chip laminate vinyl; durable and permanent; with black trim.
- Interior - attractive, NSF approved, white aluminum liner; non-rust, peel or chip. 300 series stainless steel floor.
- Insulation - entire cabinet structure is foamed-in-place using high density, CFC free, polyurethane insulation.
- 1 1/2" (39 mm) diameter dual swivel castors permit easy placement.

GLASS SLIDE LIDS

- "Low-E", single pane thermal glass lid assemblies. The latest in energy efficient technology; reduces solar heat gain and minimizes condensation.
- Designed for convenient access, fast service and attractive display.
- Lid locks standard.

MODEL FEATURES

- Self-contained, portable system. No plumbing required.
- Low profile design permits easier placement, saves aisle space.
- NSF-7 compliant for pre-packaged and bottled product.

ELECTRICAL

- Unit completely pre-wired at factory and ready for final connection to a 115/60/1 phase - 15 amp dedicated outlet. Cord and plug set included.



115/60/1
NEMA-5-15R

OPTIONAL FEATURES/ACCESSORIES

- Upcharge and lead times may apply.
- 230-240/Hz.
 - Black vinyl exterior.
 - Novelty wire baskets (accommodates 2).

PLAN VIEW

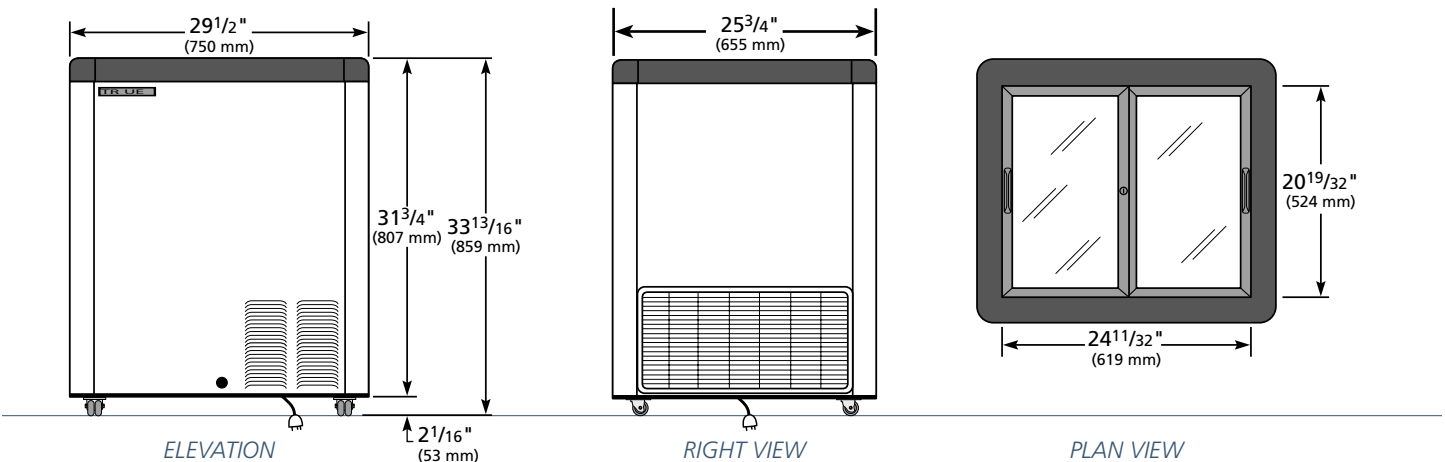

WARRANTY
 One year warranty on all parts & labor and an additional 4 year warranty on compressor. (U.S.A. only)

METRIC DIMENSIONS ROUNDED UP TO THE NEAREST WHOLE MILLIMETER
 SPECIFICATIONS SUBJECT TO CHANGE WITHOUT NOTICE



Model	Elevation	Right	Plan	3D
THF-29FL	TFEY45E	TFEY45S	TFEY45P	TFEY453

TRUE FOOD SERVICE EQUIPMENT