

TURBO AIR REFRIGERATOR MANUFACTURER
Turbo air
 more durable, convenient, beautiful

1250 Victoria St
 Carson, CA 90746
 Tel. 310-900-1000
 Fax. 310-900-1077
www.turboairinc.com

Project :	
Model # :	
Item # :	Qty :
Available W/H :	
Approval :	

Dry Bakery Case

Display Cases
 Bakery - Dry cases

Model : TB-4



FEATURES / BENEFITS

- **ENVIRONMENTALLY FRIENDLY, EFFICIENT REFRIGERATION SYSTEM**
 Turbo Air's refrigerators are designed with oversized and balanced environmentally friendly R-134A (CFC Free) refrigeration. These include large evaporators and condensers for faster cooling and balanced temperature throughout the cabinet.
- **FRAMELESS GLASS AND ELEGANT EURO DESIGN**
 The frameless all sided glass display cases provide full product visibility to optimize display effects and increase impulse sales. Its elegant contemporary euro design will not only enhance any store atmosphere but also will keep product presentation at its best and beautiful.
- **LIFT-UP, PNEUMATIC CYLINDER-ASSISTED CURVED TEMPERED FRONT GLASS**
- **SLOPED REAR DOORS FOR PRODUCT ACCESS**
- **INDEPENDENTLY WIRED SHELF LIGHTS**
- **CANTILEVERED WIRED SHELVES ADJUSTABLE UP AND DOWN, TILTED**
- **304 STAINLESS STEEL FLOOR AND AIR FLOW GRILLE**
- **HIGH-DENSITY POLYURETHANE INSULATION**
 The entire cabinet structure is foamed-in-place using high density, CFC free polyurethane insulation.
- **FOUR POINT LEVELING SYSTEM**
- **EASY ACCESS CONTROL PANEL**
- **REAR ACCESS OF COMPRESSOR COMPARTMENT FOR QUICK AND EASY SERVICE**
- **5" CASTERS STANDARD**
- **RECOMMENDED OPERATING CONDITIONS**
 TB models are designed to operate in environments where temperature & humidity do not exceed 75°F and 55% relative humidity.



Model	CU./FT.	# of Shelves	HP	AMPS	Crated Weight (lbs.)	L x D* x H† (inches)
TB-4	14.5	2	-	1.1	561	47 3/8 x 37 3/8 x 47 1/4

Model : TB-4

ELECTRICAL DATA	
Voltage	115/60/1
Plug Type	⊕ NEMA-5-20P
Full Load Amperes	1.1
Compressor HP	-
Refrigerant	-
Cord Length (ft.)	9
DIMENSIONAL DATA	
Net Capacity cu. ft.	14.5
Ext. Length Overall in.	47 ³ / ₈ (1204mm)
Ext. Depth Overall in.*	37 ³ / ₈ (950mm)
Ext. Height Overall in.†	47 ¹ / ₄ (1200mm)
Int. Length Overall in.	44 ¹ / ₈ (1123mm)
Int. Depth Overall in.	26 ¹ / ₂ (673mm)
Int. Height Overall in.	26 ¹ / ₈ (665mm)
Crated Weight lbs.	561
# of Shelves	2
Self Size	(Top) 43 ⁵ / ₈ x 16 ⁷ / ₈ (Bottom) 43 ⁵ / ₈ x 25 ⁵ / ₈

Design and specifications subject to change without notice.
Actual shipping weight may differ due to extra packing materials for product protection.
*Depth does not include 2-5/8" for door handle.
† Height does not include 5-1/4" caster height.

- **WARRANTY : 2 Year Parts and Labor Warranty**
Additional 3 Year Warranty on Compressor

- **SELF-CONTAINED SYSTEM, NO PLUMBING REQUIRED**
- **SIMPLE PLUG-IN INSTALLATION**

PLAN VIEW

(unit : inch)

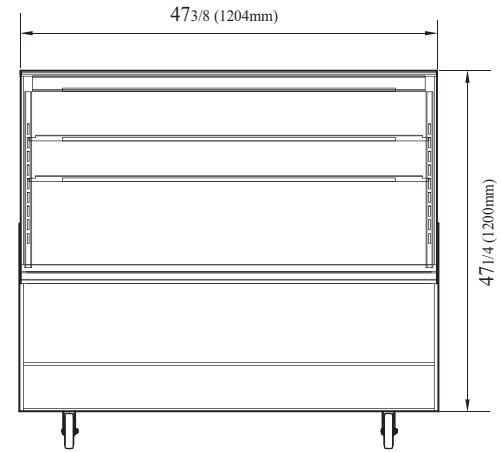

PLAN VIEW

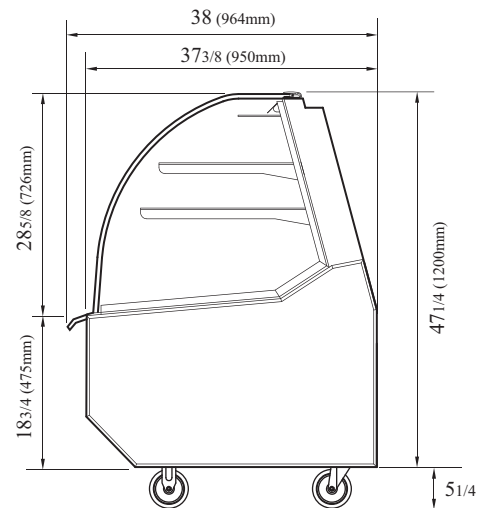

SIDE VIEW

Ver.201301



- Turbo Air : 800-627-0032 ■ GK : 800-500-3519
- Warranty : 800-381-7770 ■ AC : 888-900-1002